

SCREW REFRIGERANT COMPRESSOR
BSR SERIES



SCREW REFRIGERANT COMPRESSOR

Refrigerant: R22, R134a, R407C, R404A, R407C

Features

Variable speed + patent variable Vi ratio mechanism

- Operation frequency range (20-80Hz) + Variable Vi (1.5-3.5) - (Optional).
- Average COP achieves 10%-20% higher than constant speed model, 10%-20% saving in electricity bill.

High efficiency oil separator

- 3-stage oil separate mechanism with patent high density stainless warp-around mesh.
- Warp-around mesh design achieves low operation noise, high oil separate rate 99.7% (1% less oil carry over rate means 1% more chiller COP).

Large area suction strainer

- Larger suction strainer area can efficiently lower the suction pressure drop, raise evaporating temperature and chiller operation efficiency (COP).
- Reducing 0.1 bar pressure drop loss can increase chiller operation efficiency 4%.

Product certificate (CE/UL/PED)

- Complete unit PED certificate; Each compressor performs hydraulic test before shipment.
- Ensure product safety and reliability.



Heat pump



Petrochemical industry



Commercial air-conditioning



Process cooling



Thermo storage



Climate control

Application:

High EER, low energy consumption

- Newly designed, asymmetrical rotor profile results in a low pressure differential between lobes and flutes.
- Average COP achieves 3~5 higher than previous design, 3%-5% saving in electricity bill.

Low noise level, low vibration

- Rotors are precisely milled and dynamically balanced.
- Ensure long bearing service life and low maintenance interval.

Precise capacity control system

- Standard 4-step as well as optional linear capacity modulation system.
- Provide operations under variable loading condition with minimum power consumption.

Ease of maintenance

- Semi-hermetic design and low number of components used significantly reduce the maintenance requirement.
- Reduce spare part stock type and quantity by 30%.

Wide application range

- Compressors can be widely used in water and air cooled air-conditioning systems, thermal storage system, heat pump and industrial process, etc.
- Increase market sales opportunity by 50%.



Illustration

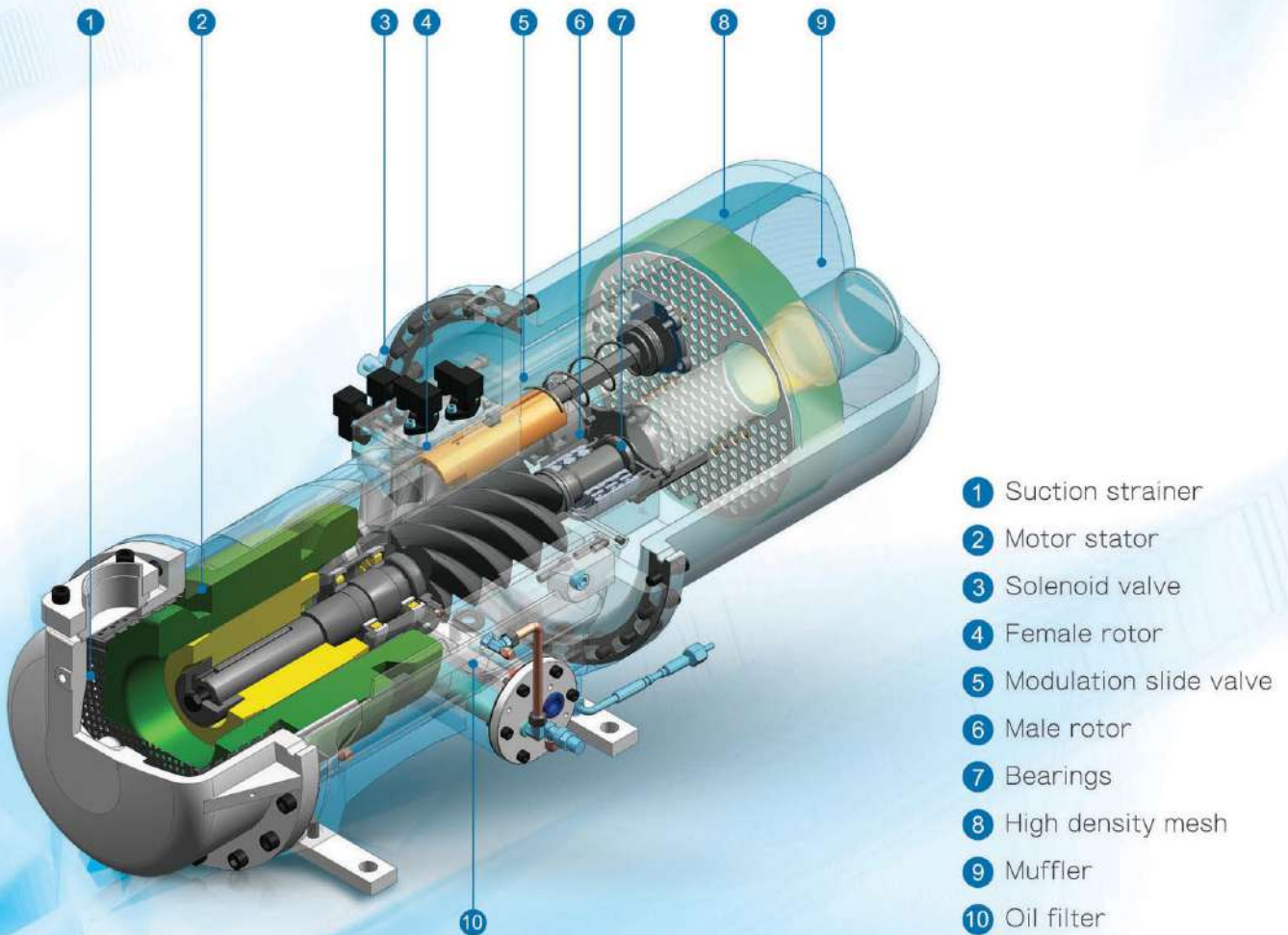

- 1 Suction strainer
- 2 Motor stator
- 3 Solenoid valve
- 4 Female rotor
- 5 Modulation slide valve
- 6 Male rotor
- 7 Bearings
- 8 High density mesh
- 9 Muffler
- 10 Oil filter

Series			BSR																
Model			213S	213	216	311S	311	314	316	321	323	324	326	413	415	421	423	424	426
Specification	Displacement (50Hz)	m ³ /hr	119	135	172	194	215	268	316	331	395	440	472	556	619	698	760	854	942
	Displacement (60Hz)	m ³ /hr	143	162	206	233	258	322	379	397	474	528	566	667	743	835	912	1025	1130
	Speed	rpm	2950 / 3550 for 50/60 Hz																
	Capacity control	%	Step control (25 / 50 / 75 / 100) or linear control (25-100)																
	Refrigerant	-	R22 / R134a / R407C / R404A / R507																
Motor	Type	-	3 phases, 2 poles, Induction motor																
	Voltage	-	380-415 - 50 Hz / 220 - 380 - 400 - 440 - 460 - 480-60Hz																
	Protection device	-	Phase loss, phase sequence, and motor PTC/PT100 thermistor																
	Start-up	-	Y-Δ start-up or direct-on-line start-up																
Dimension of suction port		Inch(mm)	2-5/8 (66.7)			3-1/8 (79.4)			4 (101.6)				5 (127.0)						
Dimension of discharge port		Inch(mm)	1-5/8 (41.3)			2-5/8 (66.7)			3-1/8 (79.4)				4 (101.6)						
Hydraulic test		kg/cm ² G	42																
Oil heater		W	150						300										
Oil charge		Liter	11			13			17				21		25				
Weight		kg	476	481	486	595	600	609	615	726	736	762	777	849	899	1115	1125	1135	1181

Operation Envelope

Range of application

Region I:
Need to operate with liquid injection and oil cooling.

Region II:
Need to operate with liquid injection or oil cooling.

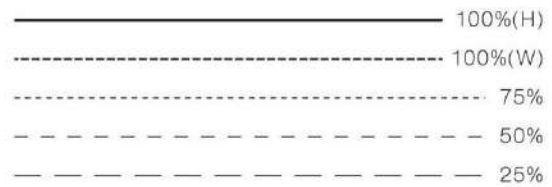

R22

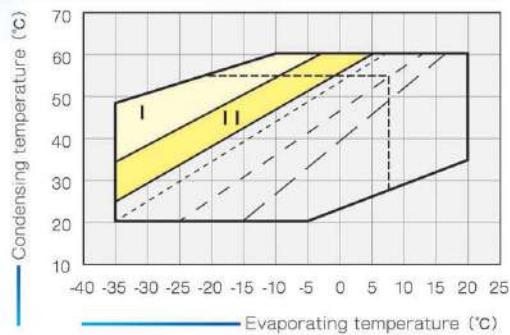

R134a

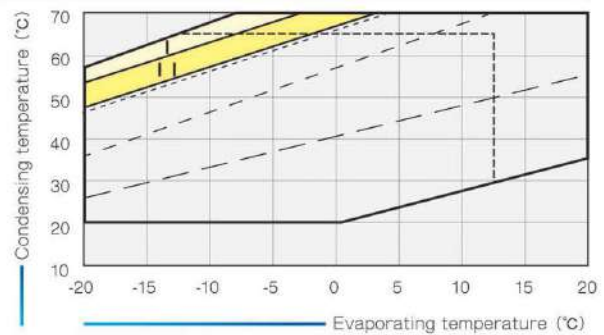

R407C

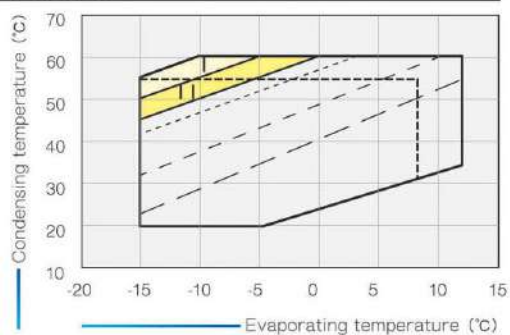

R404A / R507

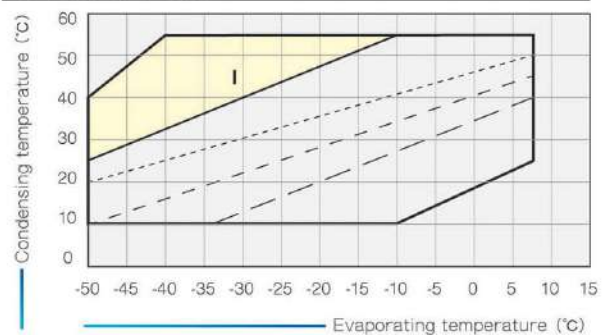

Series			BSR											
Model			427	428	516L	518L	614L	616L	513	514	516	613	614	616
Specification	Displacement (50Hz)	m ³ /hr	1058	1115	1227	1452	1762	1959	986	1099	1227	1449	1762	1959
	Displacement (60Hz)	m ³ /hr	1270	1338	1472	1743	2114	2351	1183	1319	1472	1739	2114	2351
	Speed	rpm	2950 / 3550 for 50/60 Hz											
	Capacity control	%	Step control (25 / 50 / 75 / 100) or linear control (25-100)											
	Refrigerant	-	R22 / R134a / R407C / R404A / R507											
Motor	Type	-	3 phases, 2 poles, Induction motor											
	Voltage	-	380-415- 50 Hz / 220 - 380 - 400 - 440 - 460 - 480-60Hz											
	Protection device	-	Phase loss, phase sequence, and motor PTC/PT100 thermistor											
	Start-up	-	Y-Δ start-up or direct-on-line start-up											
Dimension of suction port	Inch(mm)	5 (127.0)			6 (152.4)		8 (203.2)			6 (152.4)			8 (203.2)	
Dimension of discharge port	Inch(mm)	4 (101.6)		5 (127.0)			6 (152.4)			5 (127.0)		6 (152.4)		
Hydraulic test	kg/cm ² G	42												
Oil heater	W	300						-						
Oil charge	Liter	30		35			40			-				
Weight	kg	1300	1350	1560	1750	2200	2330	1220	1250	1280	1760	1780	1800	

Remark: Model BSR513, 514, 516, 613, 614, 614 without built-in oil separator.

BSR SERIES

High efficiency, high performance,
reliable screw refrigerant compressor



Outline dimension

BSR21X~42X

Model	A	B	C	D	E	F	G	H	I	J	K	L	M
BSR21X	1261	569	400	362	241	515	461	95	31	90	55	22	50
BSR31X	1371	574	400	425	299	581	486	121	28	110	75	22	50
BSR32X	1535	634	400	462	346	648	521	117	37	90	85	22	50
BSR41X	1649	670	500	462	334	661	538	117	30	40	76	22	60
BSR421-426	1878	752	500	590	397	827	655	115	-	115	55	25	60
BSR427/428	2044	752	500	590	499	887	654	221	69	115	55	25	60

Unit: mm

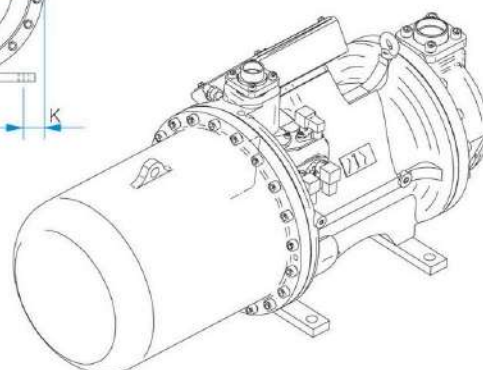
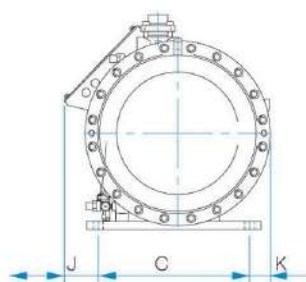
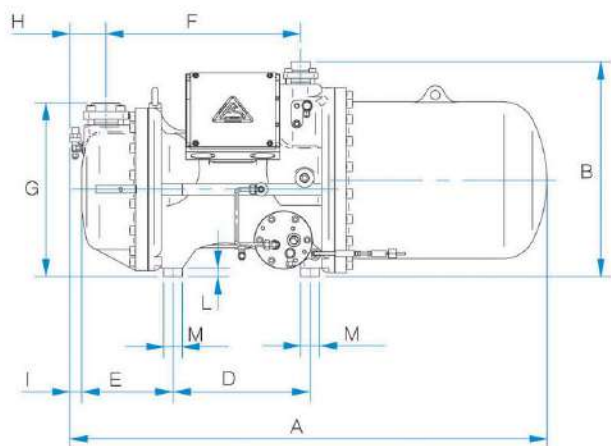

Outline dimension

BSR516L / 518L / 614L / 616L

Model	A	B	C	D	E	F	G	H	I	J	K	L
BSR516L	788	325	265	650	26	843	892	732	482	365	1094	100
BSR518L	821	325	265	650	26	841	892	842	510	365	1230	100
BSR614L / 616L	878	325	265	650	26	926	980	842	510	365	1224	70

Unit: mm

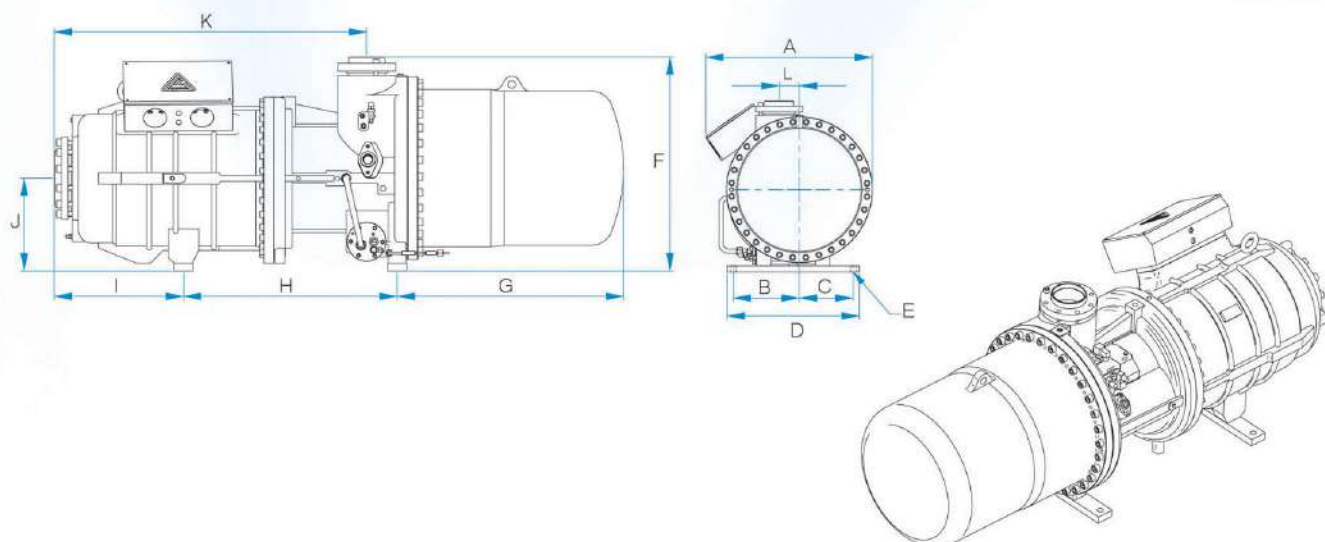

Outline dimension

BSR513 / 514 / 516 / 613 / 614 / 616

Model	A	B	C	D	E	F	G	H	I	J	K	L	M
BSR513 / 514 / 516	780	250	250	560	26	680	441	581	460	1676	344	286	482
BSR613 / 614 / 616	915	250	250	560	26	827	493	704	420	1885	449	355	468

Unit: mm

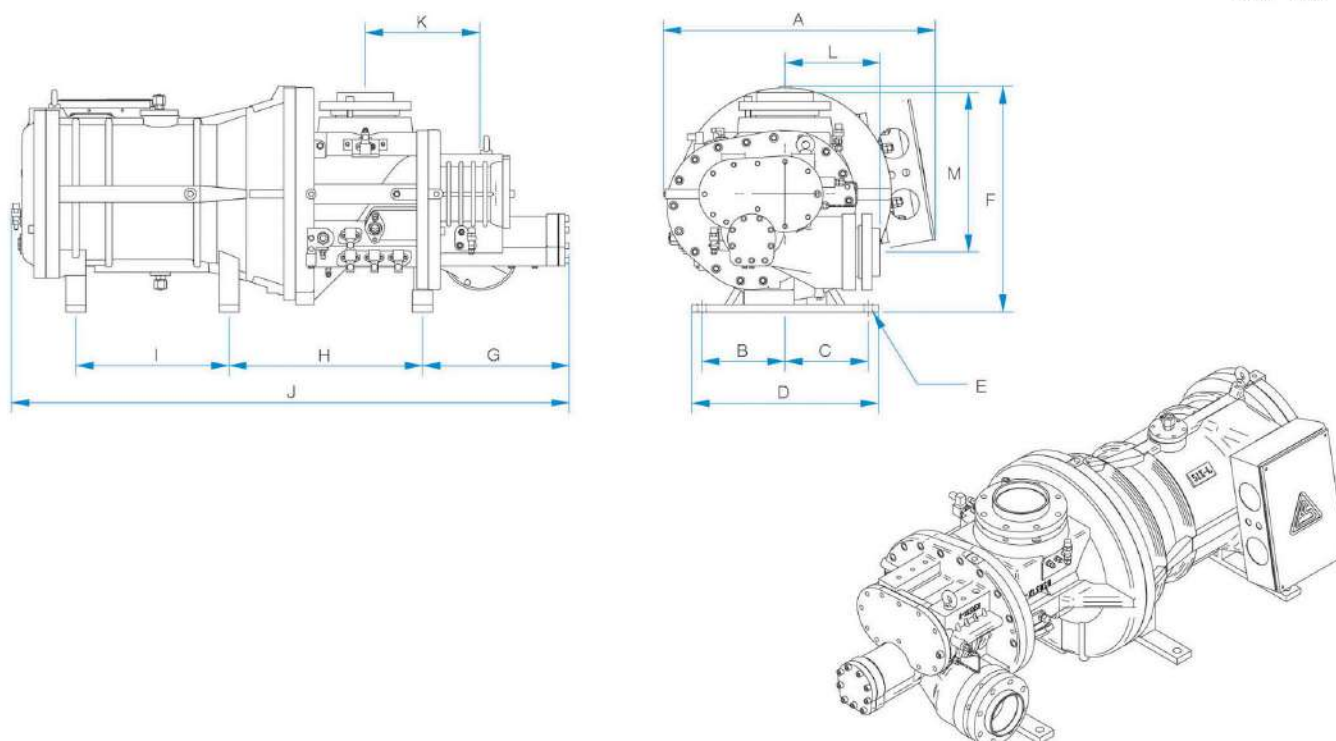



FUSHENG INDUSTRIAL CO., LTD

HEAD OFFICE

No.172, Sec. 2, Nanjing E. Rd., Zhongshan Dist.,
Taipei City 104, Taiwan (R.O.C.)
TEL : +886-2-2507-2211 FAX : +886-2-2504-7870

FACTORY(SALES OFFICE)

No.60, Sec. 2, Guangfu Rd., Sanchong Dist., New Taipei City 241,
Taiwan (R.O.C.)
TEL : +886-2-2995-1411 FAX : +886-2-2995-7925

Distributor/Sales Representative